SECTION –A (75 Marks)

1. This equation consists of (Twenty-five) multiple choice questions each carrying one mark. For each equation, four options are provided out of which exactly one is correct.

(25×1=25)

1.1 Suppose that the expectation of a random variable X is 5. Which of the following statements is true ?

- (A) There is a sample point at which X has the value 5.
- (B) There is a sample point at which X has value greater than 5.
- (C) There is a sample point at which X has a value greater than or equal to 5.
- (D) None of these

1.2 The number of binary relations on a set with n elements is:

- (A) n^2
- (B) 2^n
- (C) 2^{n^2}
- (D) None of these

1.3 The number of binary strings of n zeroes and k ones that no two ones are adjacent is

- (A) ${}^{n-1}C_k$
- (B) nC_k
- (C) ${}^nC_{k+1}$
- (D) None of these

1.4 Consider the regular expression $(0 + 1) (0 + 1) \dots$ n times. The minimum state finite automaton that recognizes the language represented by this regular expression contains

- (A) n states
- (B) n + 1 states
- (C) n + 2 states
- (D) None of these

1.5 Context-free languages are closed under:

- (A) Union, intersection
- (B) Union, Kleene closure
- (C) Intersection, complement
- (D) Complement, Kleene Closure

1.6 Let L_D be the set of all languages accepted by a PDA by final state and L_E the set of all languages accepted by empty stack. Which of the following is true?

- (A) $L_D = L_E$
- (B) $L_D \supseteq L_E$
- (C) $L_E = L_D$
- (D) None of the these

1.7 Which of the following expressions is not equivalent to \bar{x} ?

- (A) $x \text{ NAND } x$ (C) $x \text{ NAND } 1$
 (B) $x \text{ NOR } x$ (D) $x \text{ NOR } 1$

1.8 Which of the following functions implements the Karnaugh map shown below?

CD \ AB	00	01	11	10
00	0	0	1	0
01	x	x	1	x
11	0	1	1	0
10	0	1	1	0

- (A) $\bar{A}B + CD$ (C) $AD + \bar{A}B$
 (B) $D(C+A)$ (D) $(C+D)(\bar{C} + D) + (A+B)$

1.9 Listed below are some operating system abstractions (in the left column) and the hardware components (in the right column)?

- | | |
|---------------------------|--------------|
| (A) Thread | 1. Interrupt |
| (B) Virtual address space | 2. Memory |
| (C) File system | 3. CPU |
| (D) Signal | 4. Disk |
- (A) (A) - 2 (B) - 4 (C) - 3 (D) - 1 (C) (A) - 3 (B) - 2 (C) - 4 (D) - 1
 (B) (A) - 1 (B) - 2 (C) - 3 (D) - 4 (D) (A) - 4 (B) - 1 (C) - 2 (D) - 3

1.10 Which of the following disk scheduling strategies is likely to give the best throughput?

- (A) Farthest cylinder next (C) First come first served
 (B) Nearest cylinder next (D) Elevator algorithm

1.11 System calls are usually invoked by using

- (A) a software interrupt (C) an indirect jump
 (B) polling (D) a privileged instruction

1.12 A sorting technique is called stable if

- (A) it takes $O(n \log n)$ time
 (B) it maintains the relative order of occurrence of non-distinct elements
 (C) it uses divide and conquer paradigm
 (D) it takes $O(n)$ space

1.13 Suppose we want to arrange the n numbers stored in any array such that all negative values occur before all positive ones. Minimum number of exchanges required in the worst case is

- (A) $n - 1$
- (B) n
- (C) $n + 1$
- (D) None of these

1.14 If one uses straight two-way merge sort algorithm to sort the following elements in ascending order: 20, 47, 15, 8, 9, 4, 40, 30, 12, 17 then the order of these elements after second pass of the algorithm is:

- (A) 8, 9, 15, 20, 47, 4, 12, 17, 30, 40
- (B) 8, 15, 20, 47, 4, 9, 30, 40, 12, 17
- (C) 15, 20, 47, 4, 8, 9, 12, 30, 40, 17
- (D) 4, 8, 9, 15, 20, 47, 12, 17, 30, 40

1.15 The number of articulation points of the following graph is

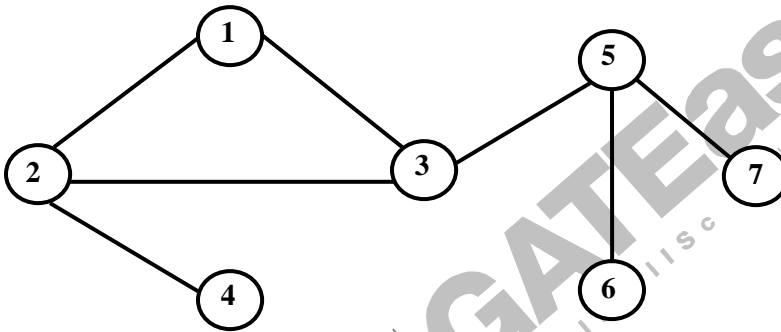

- (A) 0
- (B) 1
- (C) 2
- (D) 3

1.16 If n is a power of 2, then the minimum number of multiplications needed to compute a^n is

- (A) $\log_2 n$
- (B) \sqrt{n}
- (C) $n - 1$
- (D) n

1.17 Which of the following is the most powerful parsing method?

- (A) LL (1)
- (B) Canonical LR
- (C) SLR
- (D) LALR

1.18 Consider the join of a relation R with a relation S . If R has m tuples and S has n tuples then the maximum and minimum sizes of the join respectively are

- (A) $m + n$ and 0
- (B) mn and 0
- (C) $m + n$ and $|m - n|$
- (D) mn and $m + n$

1.19 The relational algebra expression equivalent to the following tuple calculus expression

$\{t \mid t \in r \wedge (t[A] = 10 \wedge t[B] = 20)\}$ is

- (A) $\sigma_{(A=10 \vee B=20)}(r)$ (C) $\sigma_{(A=10)}(r) \cap \sigma_{(B=20)}(r)$
 (B) $\sigma_{(A=10)}(r) \cup \sigma_{(B=20)}(r)$ (D) $\sigma_{(A=10)}(r) - \sigma_{(B=20)}(r)$

1.20 Booth's coding in 8 bits for the decimal number -57 is

- (A) 0 – 100 + 1000
 (B) 0 – 100 + 100 -1
 (C) 0 – 1 + 100 – 10 + 1
 (D) 0 0 – 10 + 100 – 1

1.21 The maximum gate delay for any output to appear in an array multiplier for multiplying two n bit number is

- (A) $O(n^2)$ (C) $O(\log n)$
 (B) $O(n)$ (D) $O(1)$

1.22 The main memory of a computer has 2 cm blocks while the cache has 2 c blocks. If the cache uses the set associative mapping scheme with 2 blocks per set, then block k of the main memory maps to the set

- (A) $(k \bmod m)$ of the cache (C) $(k \bmod 2c)$ of the cache
 (B) $(k \bmod c)$ of the cache (D) $(k \bmod 2 \text{ cm})$ of the cache

1.23 The Newton-Raphson method is to be used to find the root of the equation $f(x) = 0$ where x_0 is the initial approximation and f' is the derivative of f. The method converges

- (A) always (C) only if $f(x_0) < 0$
 (B) only if f is a polynomial (D) none of the these

1.24 Let R = (a, b, c, d, e, f) be a relation scheme with the following dependencies $c \rightarrow f$, $e \rightarrow a$, $ec \rightarrow d$, $a \rightarrow b$. Which of the following is a key for R ?

- (A) CD (C) AE
 (B) EC (D) AC

1.25 Which of the following is correct?

- (A) B-trees are for storing data on disk and B^* trees are for main memory.
 (B) Range queries are faster on B^* trees.
 (C) B-trees are for primary indexes and B^* trees are for secondary indexes.
 (D) The height of a B^* tree is independent of the number of records.

2. This equation consists of 25 (Twenty-five) multiple choice questions each carrying 2 marks. For each question, 4 options are provided out of which one or more are correct.
- 2.1 Consider two events E_1 and E_2 such that probability of E_1 , $\Pr[E_1] = 1/2$, probability of E_2 , $\Pr[E_2] = 1/3$, and probability of E_1 and E_2 , $\Pr[E_1 \text{ and } E_2] = 1/5$. Which of the following statements is/ are true?
- (A) $\Pr[E_1 \text{ or } E_2]$ is $\frac{2}{3}$ (C) Events E_1 and E_2 are not independent
(B) Events E_1 and E_2 are independent (D) $\Pr\left[\frac{E_1}{E_2}\right] = \frac{4}{5}$
- 2.2 Two girls have picked 10 roses, 15 sunflowers and 15 daffodils. What is the number of ways they can divide the flowers amongst themselves?
- (A) 1638 (C) 2640
(B) 2100 (D) None of these
- 2.3 Let L be a set with a relation R which is transitive, anti-symmetric and reflexive and for any two elements $a, b \in L$. Let the least upper bound $\text{lub}(a, b)$ and the greatest lower bound $\text{glb}(a, b)$ exist. Which of the following is/are true?
- (A) L is a poset
(B) L is a boolean algebra
(C) L is lattice
(D) None of these
- 2.4 If L_1 is context free language and L_2 is a regular language which of the following is/are false?
- (A) $L_1 - L_2$ is not context free (C) $\sim L_1$ is context free
(B) $L_1 \cap L_2$ is context free (D) $\sim L_2$ is regular
- 2.5 Given the programming constructs (i) assignment (ii) for loops where the loop parameter cannot be changed within the loop (iii) If-then-else (iv) forward goto (v) arbitrary goto (vi) non-recursive procedure call (vii) recursive procedure/function call (viii) repeat loop, which constructs will you not include in a programming language such that it should be possible, to program the terminates (i.e. halting) function in the same programming language?
- (A) (ii), (iii), (iv) (C) (vi), (vii), (viii)
(B) (v), (vii), (viii) (D) (iii), (vii), (viii)

2.6 For the schedule given below, which of the following is correct:

- | | | |
|---|---------|---------|
| 1 | Read A | |
| 2 | | Read B |
| 3 | Write A | |
| 4 | | Read A |
| 5 | | Write A |
| 6 | | Write B |
| 7 | Read B | |
| 8 | Write B | |

- (A) This schedule is serialisable and can occur in a scheme using 2PL protocol
 (B) This schedule is serialisable but cannot occur in a scheme using 2PL protocol
 (C) This schedule is not serialisable but can occur in a scheme using 2PL protocol
 (D) This schedule is not serialisable and cannot occur in a scheme using 2PL protocol.

2.7 Consider the schema $R = (S \ T \ U \ V)$ and the dependencies $S \rightarrow T$, $T \rightarrow U$, $U \rightarrow V$ and $V \rightarrow S$. Let $R = (R_1 \text{ and } R_2)$ be a decomposition such that $R_1 \cap R_2 = \emptyset$. The decomposition is

- (A) not in 2NF
 (B) in 2NF but not 3NF
 (C) in 3NF but not in 2NF
 (D) in both 2NF and 3NF

2.8 Consider the circuit shown below. In a certain steady state, the line Y is at '1'. What are the possible values of A, B and C in this state?

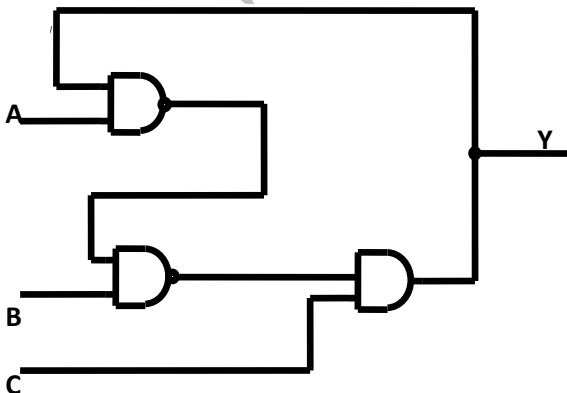

- (A) $A = 0, B = 0, C = 1$ (C) $A = 1, B = 0, C = 1$
(B) $A = 0, B = 1, C = 1$ (D) $A = 1, B = 1, C = 1$

2.9 Which of the following sets of component (s) is/are sufficient to implement any arbitrary boolean function?

- (A) XOR gates, NOT gates
(B) 2 to 1 multiplexors
(C) AND gates, XOR gates
(D) Three-input gates that output $(A \cdot B) + C$ for the inputs A, B and C.

2.10 A multi-user, multi-processing operating system cannot be implemented on hardware that does not support

- (A) Address translation
(B) DMA for disk transfer
(C) Atleast two modes of CPU execution (privileged and non-privileged)
(D) Demand paging

2.11 Which of the following is/are advantages of virtual memory?

- (A) Faster access to memory on an average.
(B) Processes can be given protected address spaces.
(C) Linker can assign addresses independent of where the program will be loaded in physical memory.
(D) Programs larger than the physical memory size can be run.

2.12 Which of the following actions is/are typically not performed by the operating system when switching context from process A to process B?

- (A) Saving current register values and restoring saved register values for process B.
(B) Changing address translation tables.
(C) Swapping out the memory image of process A to the disk.
(D) Invalidating the translation look-aside buffer.

2.13 Consider the following program in a language that has dynamic scoping:

```
var x: real;
  procedure show:
    begin print (x);end;
  procedure small;
    var x: real;
  begin x: = 0.125; show; end;
```

```
begin x:=0.25;  
  show; small  
end.
```

Then the output of the program is:

- (A) 0.125 0.125 (C) 0.25 0.125
(B) 0.25 0.25 (D) 0.125 0.25

2.14 The number of tokens in the Fortran statement DO 10 I = 1.25 is

- (A) 3 (C) 5
(B) 4 (D) None of these

2.15 A grammar that is both left and right recursive for a non-terminal, is

- (A) Ambiguous
(B) Unambiguous
(C) Information is not sufficient to decide whether it is ambiguous or unambiguous
(D) None of these

2.16 The number of full and half-adders required to add 16-bit numbers is

- (A) 8 half-adders, 8 full-adders (C) 16 half-adders, 0 full-adders
(B) 1 half-adder, 15 full-adders (D) 4 half-adders, 12 full-adders

2.17 Zero has two representations in

- (A) Sign magnitude (C) 2's complement
(B) 1's complement (D) None of these

2.18 Raid configurations of disks are used to provide

- (A) Fault tolerance (C) High data density
(B) High speed (D) None of these

2.19 Arrange the following configurations for CPU in decreasing order of operating speeds:

Hard wired control, vertical micro-programming, horizontal micro-programming.

- (A) Hard wired control, vertical micro-programming, horizontal micro-programming
(B) Hard wired control, horizontal micro-programming, vertical micro-programming
(C) Horizontal micro-programming, vertical micro-programming, hard wired control.
(D) Vertical micro-programming, horizontal micro-programming, hard wired control.

2.20 The minimum number of record movements required to merge five files A (with 10 records), B (with 20 records), C (with 15 records), D (with 5 records) and E (with 25 records) is

- (A) 165 (C) 75
(B) 90 (D) 65

2.21 If $T_1 = O(1)$, give the correct matching for the following pairs

- (M) $T_n = T_{n-1} + n$ (U) $T_n = O(n)$
 (N) $T_n = T_{n/2} + n$ (V) $T_n = O(n \log n)$
 (O) $T_n = T_{n/2} + n \log n$ (W) $T_n = O(n^2)$
 (P) $T_n = T_{n-1} + \log n$ (X) $T_n = O(\log^2 n)$
 (A) M-W, N-V, O-U, P-X (C) M-V, N-W, O-X, P-U
 (B) M-W, N-U, O-X, P-V (D) M-W, N-U, O-V, P-X

2.22 The main difference(s) between a CISC and a RISC processor is/are that a RISC processor typically

- (A) has fewer instructions
 (B) has fewer addressing modes
 (C) has more registers
 (D) is easier to implement using hard-wired control logic

2.23 A certain processor supports only the immediate and the direct addressing modes. Which of the following programming language features cannot be implemented on this processor?

- (A) Pointers
 (B) Arrays
 (C) Records
 (D) Recursive procedures with local variable

2.24 Consider the following C function definition

```
int Trial (int a, int b, int c)
{
    if ((a >= b) && (c < b)) return b;
    else if (a >= b) return Trial (a, c, b);
    else return Trial (b, a, c);
}
```

The function Trial:

- (A) finds the maximum of a, b and c (C) finds the middle number of a, b, c
 (B) finds the minimum of a, b and c (D) none of the above

- 2.25 Which of the following is/are correct?
- (A) An SQL query automatically eliminates duplicates
 - (B) An SQL query will not work if there are no indexes on the relations
 - (C) SQL permits attribute names to be repeated in the same relation
 - (D) None of the these.

SECTION – B
(75 Marks)

This section consists of TWENTY questions of FIVE marks each. ANY FIFTEEN out of them have to be answered.

3. Mr. X claims the following
If a relation R is both symmetric and transitive, then R is reflexive. For this, Mr. X offers the following proof:
“From xRy , using symmetry we get yRx . Now because R is transitive xRy and yRx together imply xRx . Therefore, R is reflexive.”
Briefly point out the flaw in Mr. X’s proof. (3)
- (A) Given an example of a relation R which is symmetric and transitive but not reflexive. (2)
4. Let G be a finite group and H be a subgroup of G . For $a \in G$, define $aH = \{ah | h \in H\}$.
(A) Show that $|aH| = |H|$ (1)
(B) Show that for every pair of elements $a, b \in G$, either $aH = bH$ or aH and bH are disjoint. (2)
(C) Use the above to argue that the order of H must divide the order of G . (2)
5. Let G be a connected, undirected graph. A cut in G is a set of edges whose removal results in G being broken into two or more components which are not connected with each other. The size of a cut is called its cardinality. A min-cut of G is a cut in G of minimum cardinality. Consider the following graph.
(A) Which of the following sets of edges is a cut?

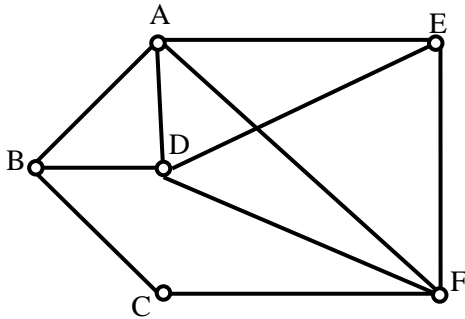

- (i) $\{(A, B), (E, F), (B, D), (A, E), (A, D)\}$
 - (ii) $\{(B, D), (C, F), (A, B)\}$ (1)
 - (B) What is the cardinality of min-cut in the graph? (2)
 - (C) Prove that if a connected undirected graph G with n vertices has a min-cut of cardinality k , then G has at least $(nk/2)$ edges. (2)
- 6.
- (A) Given that A is regular and $(A \cup B)$ is regular, does it follow that B is necessarily regular? Justify your answer. (2)
 - (B) Given two finite automata M_1, M_2 , outline an algorithm to decide if $L(M_1) \subseteq L(M_2)$ (note: strict subset). (3)
7. Show that the language $L = \{xcx \mid x \in \{0, 1\}^* \text{ and } c \text{ is a terminal symbol}\}$ is not context free if c is not 0 or 1. (5)
8. Let A be an $n \times n$ matrix such that the elements in each row and each column are arranged in ascending order. Draw a decision tree which finds 1st, 2nd and 3rd smallest elements in minimum number of comparisons. (5)
9. Let synthesized attribute val give the value of the binary number generated by S in the following grammar. For example, on input 101, 101, $S.val = 5.625$.
- $S \rightarrow LL|L$
 - $L \rightarrow LB|B$
 - $B \rightarrow 0|1$
- Write S -attributed values corresponding to each of the productions to find $S.val$. (5)

10. Suppose we have a function HALTS which when applied to any arbitrary function f and its arguments will say TRUE if function f terminates for those arguments and FALSE otherwise.

Example : Given the following function definition.

FACTORIAL (N) = IF (N = 0) THEN 1 ELSE N*FACTORIAL (N-1)

Then HALTS (FACTORIAL 4) = TRUE and HALTS (FACTORIAL-5) = FALSE

Let us define the function FUNNY (f) = IF HALTS (ff) THEN not (f f) ELSE TRUE

(A) Show that FUNNY terminates for all functions f . (2)

(B) Use (a) to prove (by contradiction) that it is not possible to have a function like HALTS which for arbitrary functions and inputs says whether it will terminate on that input or not. (3)

11. Consider the following algorithms. Assume, procedure A and procedure B take $()$ (1) and $()$ (1/n) unit of time respectively. Derive the time complexity of the algorithms in $()$ -notation. (3)

```

algorithm what (n)
begin
    if n = 1 then call A
    else begin
        what (n - 1);
        call B (n)
    end
end.
    
```

(A) Write a constant time algorithm to insert a node with data D just before the node with address p of a singly linked list. (2)

12. (A) In a binary tree, a full node is defined to be a node with 2 children. Use induction on the height of the binary tree to prove that the number of full nodes plus one is equal to the number of leaves. (3)

(B) Draw the min-heap that result from insertion of the following elements in order into an initially empty min-heap : 7, 6, 5, 4, 2, 3, 1. Show the result after the deletion of the root of this heap. (2)

13. An instruction pipeline consists of 4 stages : Fetch (F), Decode operand field (D). Execute (E) and Result-Write (W). The 5 instructions in a certain instruction sequence need these stages for the different number of clock cycles as shown by the table below.

Number of clock cycles needed for

Instruction	F	D	E	W
1	1	2	1	1
2	1	2	2	1

3	2	1	3	2
4	1	3	2	1
5	1	2	1	2

Find the number of clock cycles needed to perform the 5 instructions.

(5)

14.

(A) Show that the formula $[(\sim p \vee q) \Rightarrow (q \Rightarrow p)]$ is not a tautology. (3)

(B) Let A be a tautology and B be any other formula. Prove that $(A \vee B)$ is a tautology. (2)

15. What will be the output of the following program assuming that parameter passing is

(i) call by value

(ii) call by reference

(iii) call by copy restore

```

procedure P (x, y, z);
    begin y := y + 1 ; z := z + x end;
begin
    a := 2 ; b := 3;
    P (a + b, a, a);
print (a)
end.
```

(5)

16. Consider the following Pascal program skeleton

```

program sort (...);
var a, x, ...;
procedure readarray ;
    var i, ...;
    begin
        ... := ...a ...
    end;
procedure exchange (...);
    begin
        ... := ...a ...;
        ... := ...x ...;
    end;
Procedure qsort (...);
var k, v, ...;
function partition (...) ...;
    var i, j, ...;
    begin
        ... := ...a ...;
```

```

... := ...v ...;
end ;
begin
    :
end :
begin
:
end.

```

Assume that at a given point in time during program execution, following procedures are active: sort, qsort(1, 9), qsort(1, 3), partition(1, 3), exchange(1,3)

Show snapshots of the runtime stack with access links after each of the activations.

17. Consider the following program fragment in the assembly language of a certain hypothetical processor. The processor has three general purpose registers R1, R2 and R3. The meanings of the instructions are shown by comments (starting with ;) after the instructions.

```

X:   CMP R1, 0    ; Compare R1 and 0, set flags appropriately in status register
      JZZ        ; Jump if zero to target Z.
      MOV R2, R1 ; Copy contents of R1 to R2.
      SHR R1     ; Shift right R1 by 1 bit.
      SHL R1     ; Shift left R1 by 1 bit.
      CMP R2, R1 ; Compare R2 and R1 and set flag in status register.
      JZY        ; Jump if zero to target Y.
      INC R3     ; Increment R3 by 1;
Y:   SHR R1     ; Shift right R1 by 1 bit
      JMP X ; Jump to target X.

```

Z :

(A) Initially, R1, R2 and R3 contain the values 5, 0 and 0 respectively, what are the final values of R1 and R3 when control reaches Z ?

(2)

(B) In general, if R1, R2 and R3 initially contain the values n, 0, and 0 respectively. What is the final value of R3 when control reaches Z?

(3)

18. Design a $2K \times 8$ (2048 locations, each bit wide) memory system mapped at addresses $(1000)_{16}$ to $(17FF)_{16}$ for the 8085 processor using four $1K \times 4$ memory chips. Each of these chips has the following signal pins :

- (i) \overline{CS} (Chip select, data lines are in high impedance state when it is 1)
- (ii) \overline{RD} (0 for read operation)
- (iii) \overline{WR} (0 for write operation)

- (iv) A_0, A_1, \dots, A_9 (input address lines. A_0 is the least significant)
 (v) D_0, D_1, D_2, D_3 , (bi-directional data lines. D_0 is the least significant) (5)

19. A certain computer system has the segmented paging architecture for virtual memory. The memory is byte addressable. Both virtual and physical address spaces contain 2^{16} bytes each. The virtual address space is divided into 8 non-overlapping equal size segments. The memory management unit (MMU) has a hardware segment table, each entry of which contains the physical address of the page table for the segment. Page table are stored in the main memory and consists of 2 byte page table entries.

- (A) What is the minimum page size in bytes so that the page table for a segment requires atmost one page to store it ? Assume that the page size can only be a power of 2. (2)
 (B) Now suppose that the page size is 512 bytes. It is proposed to provide a TLB (translation look-aside buffer) for speeding up address translation. The proposed TLB will be capable of storing page table entries for 16 recently referenced virtual pages, in a fast cache that will use the direct mapping scheme. What is the number of tag bits that will need to be associated with each cache entry? (1)
 (C) Assume that each page table entry contains (besides other information) 1 valid bit, 3 bits for page protection and 1 dirty bit. How many bits are available in page table entry for storing the aging information for the page? Assume that the page size is 512 bytes.

20.

- (A) A certain processor provides a 'test and set' instruction that is used as follows.
 TSET register.flag
 This instruction atomically copies flag to register and sets flag to 1. Give pseudocode for implementing the entry and exit code to a critical region using this instruction. (2)
 (B) Consider the following solution to the producer-consumer problem using a buffer of size 1. Assume that the initial value of count is 0. Also assume that the testing of count and assignment to count are atomic operations.

Producer

Repeat

Produce an item;
 if count = 1 then sleep;
 Place item in buffer.
 count = 1;
 wakeup (Consumer);

Forever

Consumer:

Repeat
if count = 0 then sleep:
Remove item from buffer:
count = 0:
wakeup (Producer):
Consumer item:
Forever:

Show that in this solution it is possible that both the processes are sleeping at the same time.

(3)

21. Consider a B-tree with degree m . That is, the number of children, c , of any internal node (except the root) is such that $m \leq c \leq 2m - 1$. Derive the maximum and minimum number of records in the leaf nodes for such a B-tree with height h . $h \geq 1$. (Assume that the root of a tree is at height 0.)

(5)

22. Consider the set of relations

EMP (Employee-no, Dept-no, Employee-name; Salary)

DEPT (Dept-no, Dept-name, Location)

Write an SQL query to:

(a) Find all employee names who work in departments located at 'Calcutta' and whose salary is greater than Rs. 50,000

(2)

(b) Calculate, for each department number, the number of employees with a salary greater than Rs. 1,00,000.

(3)